

Dimmer Module 100W

101345

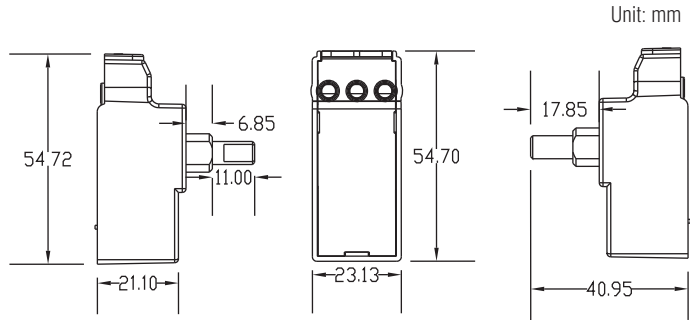

Thank you for purchasing this unit. Please read the instructions carefully before use to ensure safe and satisfactory operation of this product. Please retain these instructions for future reference.



⚠ ⚠ DANGER

HAZARD OF ELECTRIC SHOCK, EXPLOSION OR ARC FLASH

- Turn off all power supplying this equipment.
 - Use a voltage tester of appropriate rating.
- Failure to follow these instructions will result in death or serious injury.

⚠ WARNING

HAZARD OF FIRE

Failure to follow these instructions can result in death, serious injury, or equipment damage.

Noted: To use with products with high inrush current (such as LED Panel/Tape), please use with Inrush Current Limiter. Otherwise, the dimmer could be damaged.

WIRING DIAGRAM

Diagram 1: Using a 1 or 2 way dimmer switch

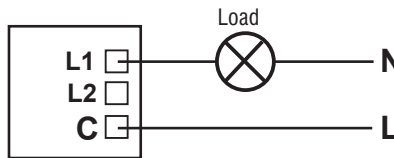

Diagram 2: Using a 2 way dimmer switch
Dimmer must replace only one of the 2 way switches

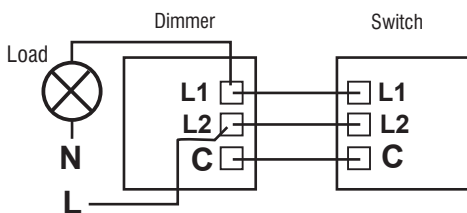
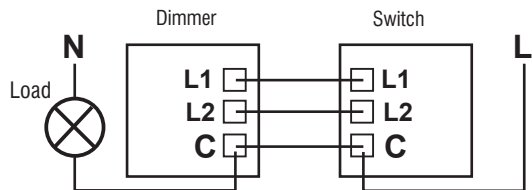

Diagram 3: Using a 2 way dimmer switch
Dimmer must replace only one of the 2 way switches



INSTALLATION

1. Switch off the mains supply before commencing the installation.
2. If removing the existing switch, disconnect the wiring from the switch terminals at the rear and take note of the present wiring of the switch and the marking on the terminals.
3. Ensure that any mounting box is free of plaster lumps or projecting screw heads. Most models can be fitted into a box with a minimum depth of 25mm.
4. Terminate the dimmer switch in accordance with the diagrams in the Wiring Instructions section. Take care that no bare wires project out of the terminals. Keep wires together in a terminal if they were together in your old switch.
5. After connecting the wires screw the dimmer switch gently into the wall box so that the front plate does not distort or crack. Do not trap the wiring between the rear of the dimmer and the back of the wall box.
6. Once installation is complete, switch on the mains supply. When switching on the dimmer for the first time you might need to set up the min. brightness and Max. brightness, dimming mode as well.

OPERATION

Factory Reset

When first installed the dimmer or replace new lights, a factory reset action is required to get the optimal dimming performance.

* Reset the Min. bright level:

1. Switch on and set the dimmer knob to the MINIMUM position (turn fully anti-clockwise).
2. Push the knob for 8 times.
3. The lights will step up and down in brightness for twice to show that the dimmer is in CONFIGURATION MODE, then either stay at a low light level or go off.

* Adjust the min brightness level:

1. After factory reset, slowly adjust to the brightness that you are satisfied with. Leave the dimmer in this position.
2. Push the knob for 4 times until the light step up and down in brightness for once, the setting saved.

* Change the dimming mode from Trailing edge to Leading edge:

The dimmer default setting is trailing edge dimming to change into leading edge dimming please refer to Instruction below:

1. Turn on the load and set the lights into maximum brightness.
2. Switch on and off the load 5 times the load will flash twice to show dimmer is in leading edge mode.

Note: To switch back into trailing edge mode just repeat the operation again the load will flash once to show the dimmer is back in trailing edge dimming mode again.

Technical data

Operating Voltage:	220-240V~
Frequency:	50Hz
Maximum Load:	100W
Minimum Load:	5W
Dimming Mode:	Universal
Control Method:	Two way
Dimmable LED lamps:	5-100VA (Max. 10 LEDs)
LV Halogen lighting with electronic transformers:	10-150W
Incandescent lighting:	10-150W



Conformity with all relevant UKCA Directive requirements.



Conformity with all relevant EC Directive requirements.



Waste electrical products should not be disposed of with household waste. Please recycle where facilities exist. Check with your Local Authority or local store for recycling advice.



This product is not a toy. Keep away from children and animals.



Do not expose this product to moisture, water or other liquids.



Do not attempt to examine or repair this product yourself.



This product is designed for indoor use only. Do not use outside!